



# Wood-Core Series Storm Doors INSTALLATION INSTRUCTIONS

Before You Get Started.....Page 1  
 Installation Instructions .....Pages 2–9  
 Closure Installation Instructions .....Pages 8–9  
 Troubleshooting.....Page 10  
 Warranties.....Page 11  
 General Care and Maintenance.....Page 12

Visit our web site at [www.larsondoors.com](http://www.larsondoors.com)



**Congratulations!** You've purchased a quality-built wood core storm/screen door from Larson. Please take a moment to fill out and mail in your product warranty card for years of trouble-free service. See page 11 for warranty details. **NOTE:** Modification of door will void warranty. **Retain instruction booklet and sales receipt for future reference.**

If you have any questions regarding the installation of your Larson storm door or need to order replacement parts, do not go back to the store, call our **Homeowner's Helpline** at **1-888-483-3768**. Our staff of storm door experts are on hand to answer any questions you may have. Please have the following information on hand when you call: (1) Warranty Registration number—the number is on a decal located on the hinge z-bar (door must be open to view once installed) (2) Model of door (3) Size of the door (4) Color.

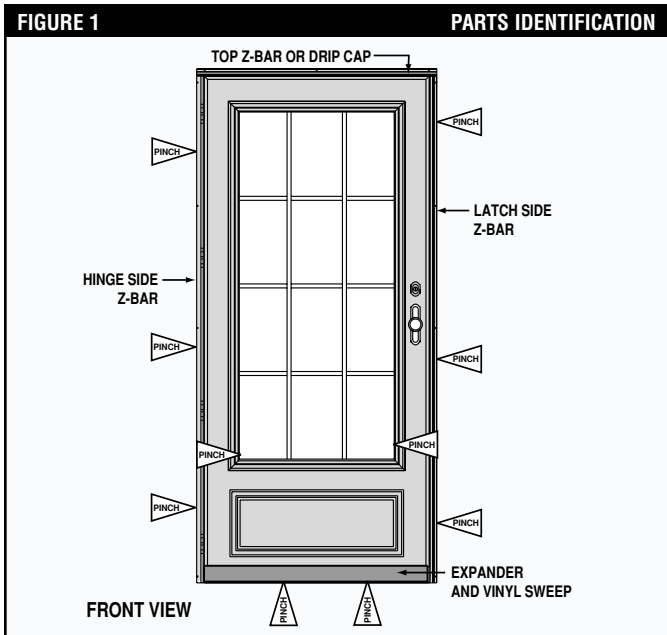

## READ BEFORE BEGINNING INSTALLATION.

1. The door requires caution while installing and during its total operational life.
2. **The door is heavy and requires two people to lift and install on your home or business.**
3. Pinch points are indicated in the instructions by this symbol. Children should not be allowed to play with the door and should be made aware of the pinch points by the owner. Failure to properly instruct the user of this product could result in the loss of a finger or other injury.
4. Do not operate the storm door without closer(s) installed and adjusted to prevent door slamming.
5. Eye protection must be used during the installation to prevent damage from flying particles.
6. Do not modify or alter the installation and specified use of the door.
7. Read the complete installation instructions before proceeding with installation.

**NOTE:** Larson Manufacturing Company is not responsible for accidents and injury resulting from the use or installation of this product.

### TOOLS NEEDED

- |   |   |
|---|---|
| 1. Power drill with assorted bits                 | 7. Hammer   |
| 2. Phillips head screwdriver, regular screwdriver | 8. Pencil   |
| 3. Hacksaw  | 9. Pliers   |
| 4. Caulking gun with caulking                     | 10. Saw horses  |
| 5. Tape measure                                   | 11. Small wood chisel                                 |
| 6. Square and level                               | 12. Hole saw or spade bit - per hardware instructions |

**Larson recommends having another person help you install your storm door.** A cordless drill with a screw driver bit is recommended. Assembly may require shimming to fit existing opening (shims not included).

### BEFORE YOU GET STARTED

- ▶ Verify opening size with size shown on the box label.
- ▶ All Larson doors are down sized to fit the opening.
- ▶ Remove the window sashes so your door is lighter while installing (Refer to Step #12).
- ▶ Remove hardware box from inside door carton.
- ▶ Remove the expander from the door (will be applied later). See Figure #1
- ▶ Make sure house door trim is securely nailed to support your new storm door.
- ▶ Check box for any **INSTRUCTION REVISIONS** (printed on colored paper). Instruction revisions take precedence over printed manual.

# 1 Determine Left or Right Hinge Side

Your Larson storm door is Reversa-Hinge™ meaning that the door is designed for either right hand or left hand hinge installation. Looking at your door opening from the outside, determine which side you want the hinge on. (See Figure 2)

**IMPORTANT NOTICE:** If you choose to have the storm door handle on the same side as your prime door hardware, you **MUST** verify that there will be **NO** interference between the two handles or hardware.

Your storm door handle will be 39-1/2" down from the top of the opening. If the prime door hardware is at this height, it is likely to interfere with the storm door hardware.

If this is the case, we recommend you hinge the storm door on the same side as your prime door hardware so the storm door handle is opposite your prime door handle.

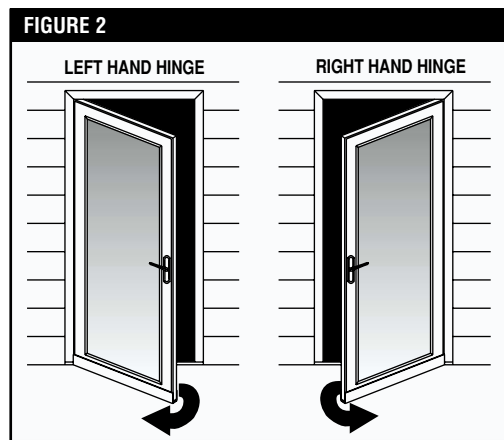

# 2 Install Hinge on Door

The "hinged Z-bar assembly" (or hinged door frame) is packaged unattached. It can be mounted to either side of the door.

Lay the door flat on saw horses (outer front face of door facing up). **To verify outside from inside of your door. . glass and screen inserts are removed and installed from the inside.** Place the "hinge Z-bar assembly" on the edge of the door as shown with each hinge leaf turned down (see Figure 3). Check to see that the aluminum Z-bar is orientated as shown in illustrations (Figure 5, for a left-hand hinged door), or (Figure 6, for a right-hand hinged door).

Move "hinge Z-bar assembly" up or down until the top of the z-bar hangs over the top edge of the door 1/16"–1/8". (See Figure 4) Mark the top hole of the top hinge and drill an 1/8" pilot hole. Install one #8x1" unpainted pan head screw. **The top end of the Z-bar MUST overhang the top of the door 1/16" to 1/8"**. The bottom end will be cut to length later.

Align each hinge leaf along the edge of the door, drill 1/8" pilot holes, and complete the attachment of each hinge to the door using the remaining #8x1" unpainted pan head screws.

NOTE: Hinged Z-bar must swing after securing hinges to the door.

Rotate per Figure 3.

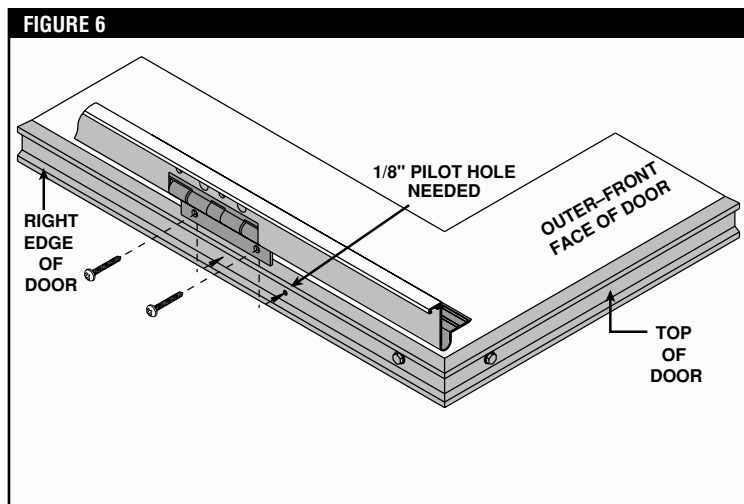
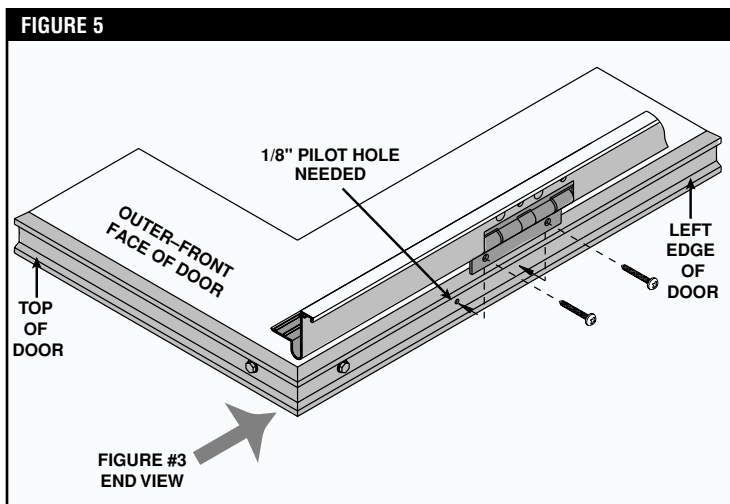
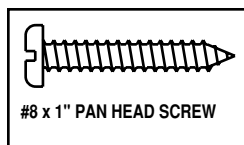
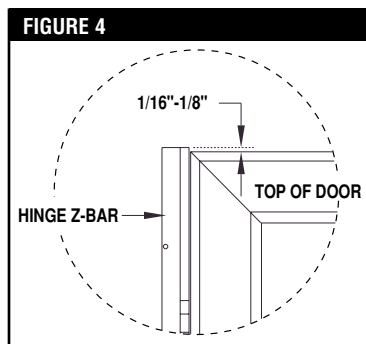
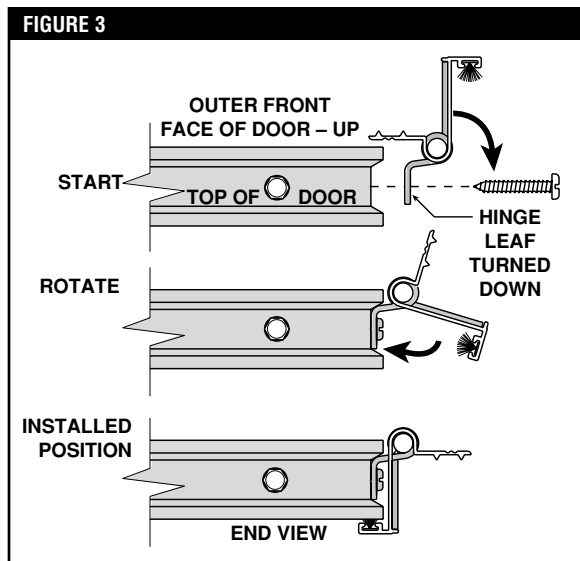

### 3 Measure the Opening Height

Facing the house from the outside, measure the height of the opening as illustrated in Figure 7. This measurement is taken from the top of the door opening (underside of the trim board) down to the bottom threshold.

Take two measurements (A and B) as shown to determine the threshold angle to cut the Z-bar.

### 4 Cut Hinge-Side Z-Bar to Length

The top of the z-bar should be at the correct position—1/16" to 1/8" above the door. The bottom of the z-bar must be cut to the correct length (opening height), taking into account the angle of the threshold. See Figure 8.

Using the measurements taken in step 3, determine the angle to cut the z-bar. Transfer this measurement to the z-bar, then make a cut 1/16" less than your measurement to allow room for top drip cap. Save the z-bar cut-off scrap for steps 6 and 10.

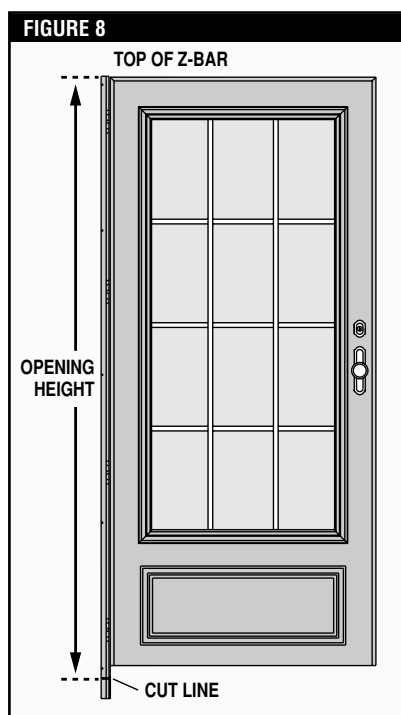

### 5 Install Expander Sweeps

**NOTE:** This does **NOT** apply to models with vinyl expanders. Vinyl expanders have integrated sweeps.

Remove the expander from the door if you haven't already. Some models come with a single sweep, others come with a double sweep.

To install the sweep, simply thread the sweep into the channel of the expander. With the sweep installed, crimp both ends of the expander channel with a pliers.

**NOTE:** For best results crimp the inner leg of the channel—only, at both ends of the expander (see Figure 9).

**FOR THE DOUBLE SWEEP ONLY:**

You must bend the rubber sweep out of the way while crimping.

FIGURE 7

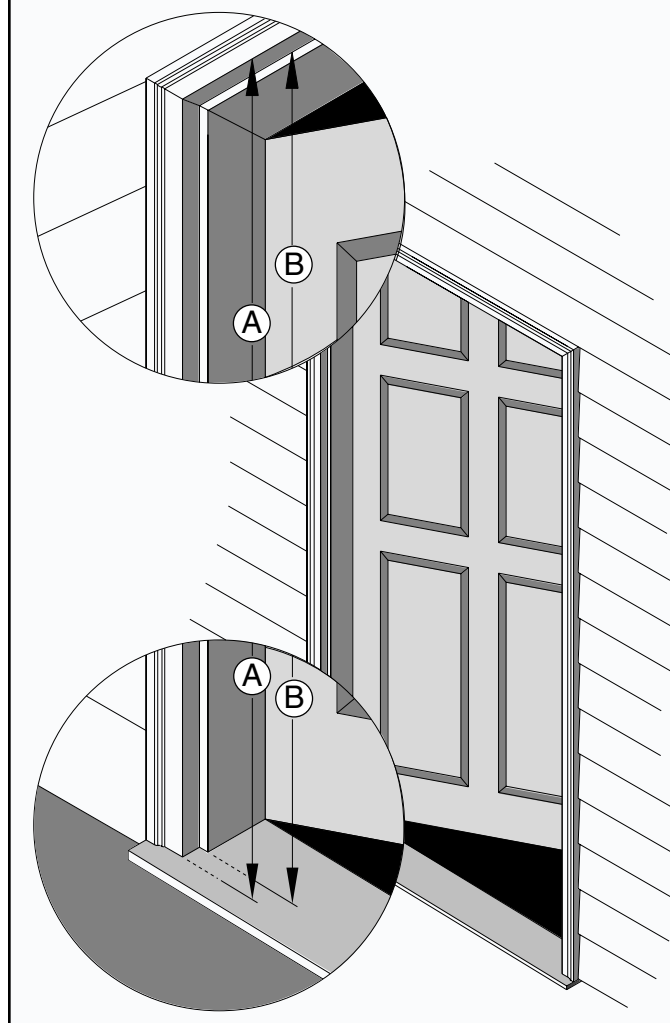
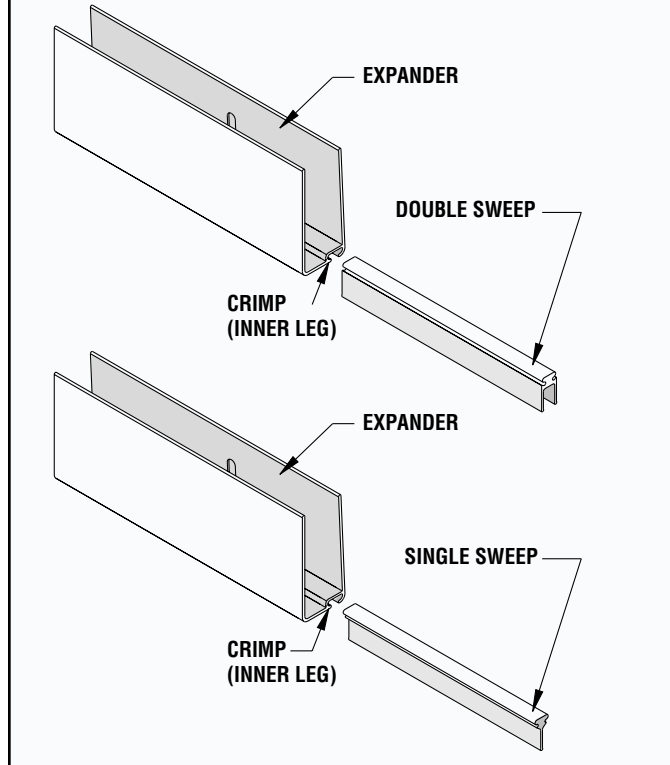
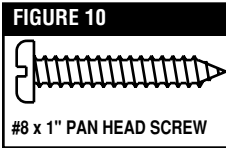

FIGURE 9



## 6 Secure Door to Opening

Place the door in the opening with the hinge-side Z-bar tight against the door trim or wood frame. Temporarily install just two of the painted #8 x 1" pan head screws (Figure 10) on the front of the hinge-side Z-bar. Install one screw next to the top hinge and one next to the bottom hinge. Be sure not to over tighten the screws and crush down the Z-bar.



Set the cut-off scrap piece of Z-bar from step 4 in place between the door and up against the wood trim on the latch side of the door as shown in Figure 11.

From the outside of the house with the door closed, check the distance between the side of your Larson storm door and the scrap Z-bar. If this distance is greater than 1/4", a wood spacer can be placed between the hinge-side or latch-side Z-bar and the wood jamb. (Figure 12)

If a wood spacer is needed, remove the door, add the spacer and reinstall. Spacer thickness should not exceed 1/4" and longer screws should be used to properly secure the door to the jamb. (A wood spacer can also be used on the latch side Z-bar.)

**NOTE: Wood spacers and longer screws are not included.**

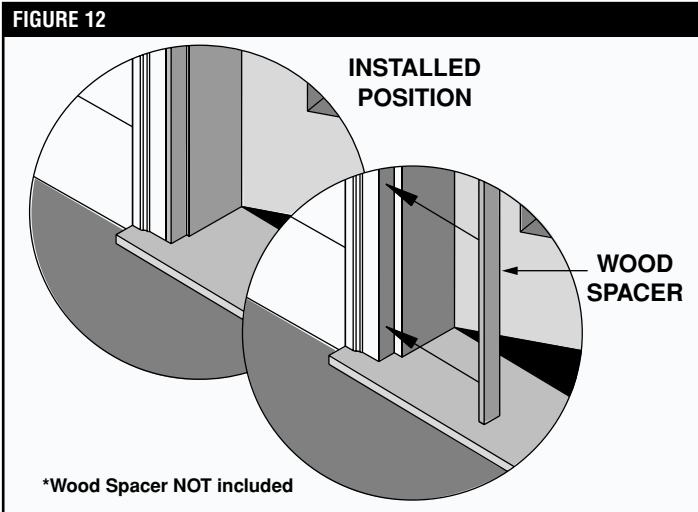
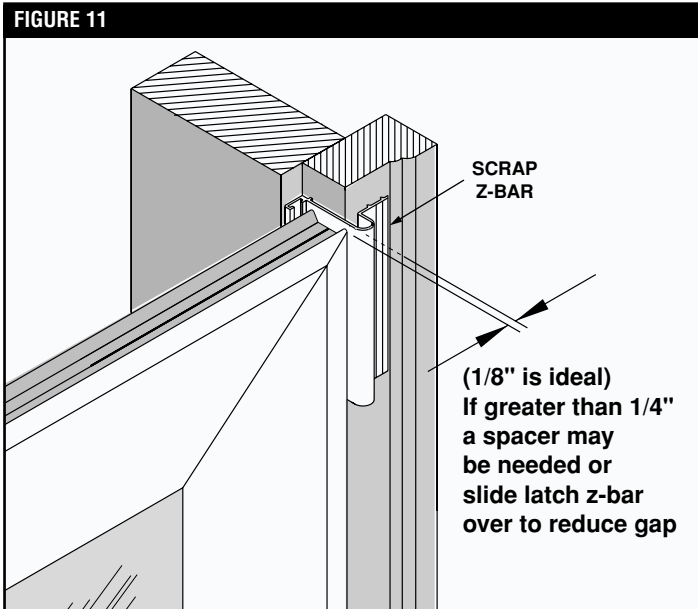

## 7 Secure Hinge-Side Z-Bar

With the door properly fit in the opening, open the door to expose the hinges. You will see two (2) pre-punched holes at each hinge plate. Using eight (8) #8x1" flat head screws (Figure 13), attach each hinge plate to the wood jamb. Screw heads must be flush with the hinge surface.

Install the remaining #8x1" painted pan head screws (Figure 14) in the outside of the hinge-side Z-bar.

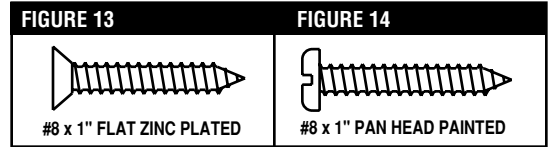

## 8 Install the Drip Cap

The drip cap goes above the door and z-bars. Place the top drip cap into position as shown in Figure 15. Close the door. From outside the door, the gap between the top of the door and the drip cap should be 1/16" to 1/8" as shown in Figure 15. Attach the drip cap with #8x1" painted pan head screws provided. **Caulk along the edge of drip cap.**

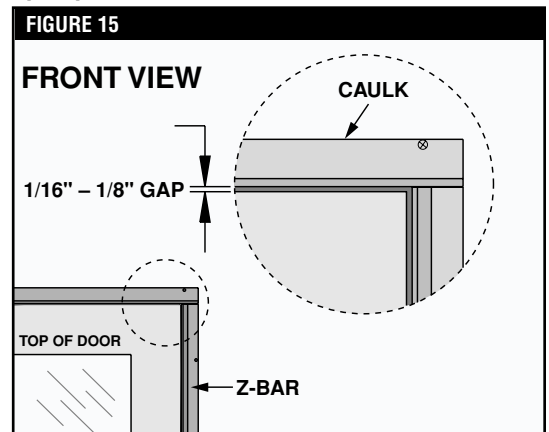

# 9 Install Latch Side Z-Bar

Larson offers three types of hardware: Surface-mount, Mortise (with deadbolt) and Mortise (without deadbolt). The latch side z-bar installation varies per hardware type. Determine which hardware type you have, then proceed with latch side z-bar installation. **Identification Hints:** No holes in latch side z-bar = **Surface Mount Hardware**

Latch side z-bar is 83" long = **Mortise Hardware (with deadbolt)**

Latch side z-bar is 81" long = **Mortise Hardware (without deadbolt)**

9a

## Surface-Mount Hardware Models

(see Figure 16)

Measure and cut latch side z-bar using same method as outlined in Step 4.

Set the z-bar in place between the door and the wood jamb. Allow a gap of approximately 1/8" between the door and the latch-side z-bar. Make sure the door closes freely without hitting the z-bar, but also makes good contact with woolpile weatherstripping. Fasten z-bar using #8x1" painted panhead screws through the pre-drilled holes provided in z-bar.

FIGURE 16

### HOW TO IDENTIFY

- No Holes In Z-bar

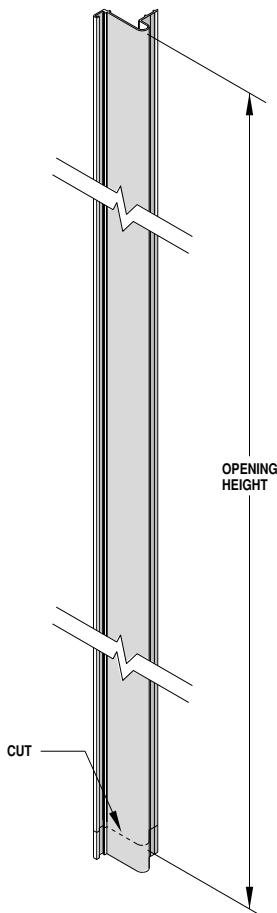

9b

## Mortise Hardware (with Deadbolt) Models

(see Figure 17)

**NOTE: TWO cuts must be made.**

**Top Cut:** First, determine which end of the z-bar is top and mark it with a piece of tape. Measure up 37-1/8" from the top of the slot, mark, then cut the z-bar.

**Bottom Cut:** Cut the z-bar to length (use the same procedure used to cut the hinge-side z-bar back in Step 4).

**Installation:** Set the z-bar in place between the door and the wood jamb. Allow a gap of approximately 1/8" between the door and the latch-side z-bar. Make sure the door closes freely without hitting the z-bar, but also makes good contact with woolpile weatherstripping. Fasten z-bar using #8x1" painted panhead screws through pre-drilled holes provided in z-bar.

FIGURE 17

### HOW TO IDENTIFY

- 83" Z-bar

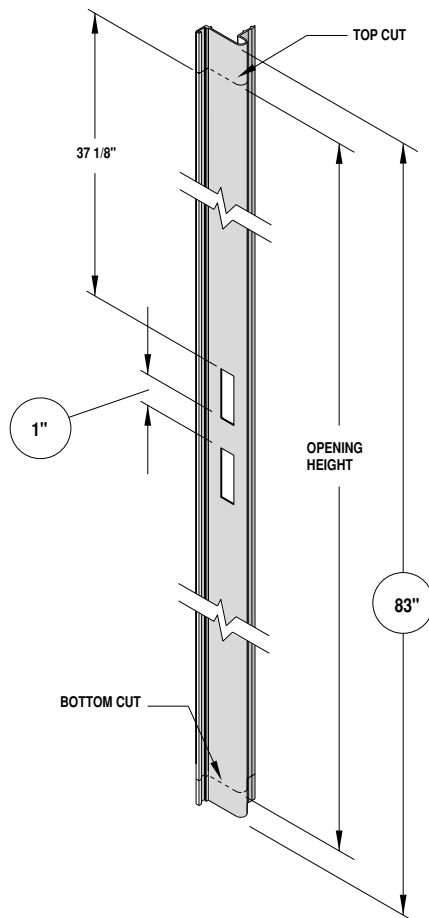

9c

## Mortise Hardware (without Deadbolt) Models

(see Figure 18)

Measure and cut latch side z-bar using same method as outlined in Step 4.

**IMPORTANT: Cut the bottom of the z-bar. Do NOT cut the top!**

Set the z-bar in place between the door and the wood jamb. Allow a gap of approximately 1/8" between the door and the latch-side z-bar. Make sure the door closes freely without hitting the z-bar, but also makes good contact with weatherstripping. Fasten z-bar using #8x1" painted panhead screws through the pre-drilled holes provided in z-bar.

FIGURE 18

### HOW TO IDENTIFY

- 81" Z-bar

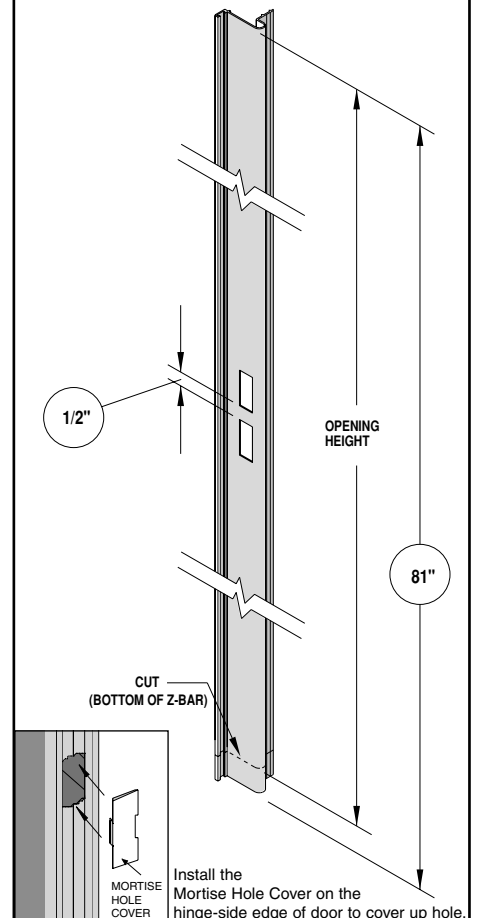

## 10 Install Latch Hardware

Refer to separate instructions packaged in the hardware box.

**\*CAUTION:** Be sure to install storm door hardware at a height that will not interfere with the prime door hardware.

**\*Retain the parts list for future reference.**

## 11 Install / Adjust the Bottom Expander

Install expander at the bottom of the door with the slotted holes to the inside. Adjust the bottom expander so that the vinyl sweeps touch the door threshold. Centrally locate the two #6x3/8" pan head screws in the slot to allow for future adjustments.

Drill 3/32" diameter pilot holes for the screws, being careful not to drill all the way through to the front face of the door, then install screws.



## 12 Glass/Screen Insert—(Installation & Removal)

### 12a Full-Lite Models

#### INSTALLATION

Your door is shipped with the screen and glass inserts in the window opening. After the door is installed either the screen or glass is held in place by plastic retainer strips.

To install retainers, start one end of the retainer into the track at the top or bottom of the window and push retainer into the track as shown. Continue to snap retainer into place from that end (moving toward the opposite end in increments of 4–5"). At the end, you will hear a "snap" as the last portion of the retainer goes in. See Figure 19.

#### REMOVAL

Place sharp flat-nose screwdriver blade in groove next to door frame (approximately 1/2" from top or bottom of window) and pry end of retainer loose. Grasp retainer and remove. (See Figure 20)

FIGURE 19

#### INSTALLATION

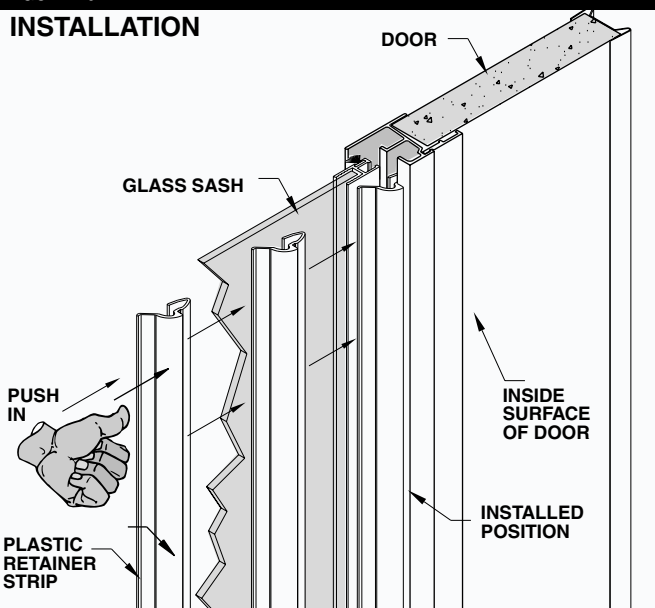

**ATTENTION:**  
When installing glass insert (when installed correctly) will be held tight by vinyl retainer strips.

**CAUTION!**  
If glass insert is loose—vinyl retainer strips are **NOT** installed correctly. Remove retainer strips and re-install them per the instructions.

FIGURE 20

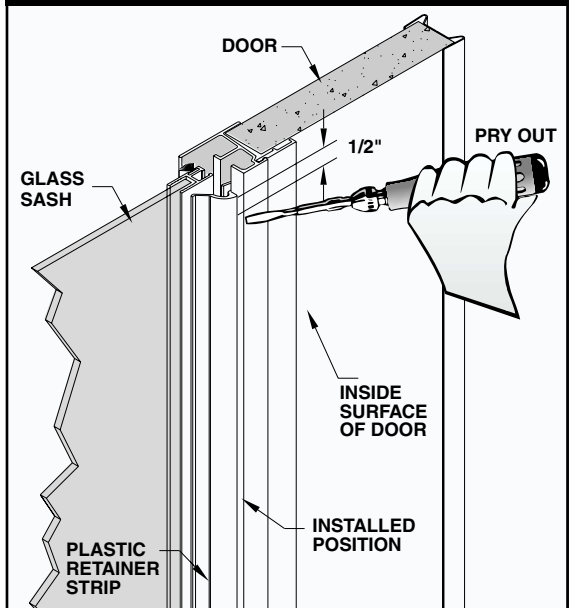

### 12b Self-Storing (Half-Screen) Models (Figure 21)

1. Remove bottom glass sash from door.
2. Remove screen by lifting up top glass sash which rests on top of the screen and pulling out on top of screen. Also, you can disengage the top glass finger pulls and pull out both the glass and screen at the same time.
3. Remove top glass sash.

FIGURE 21

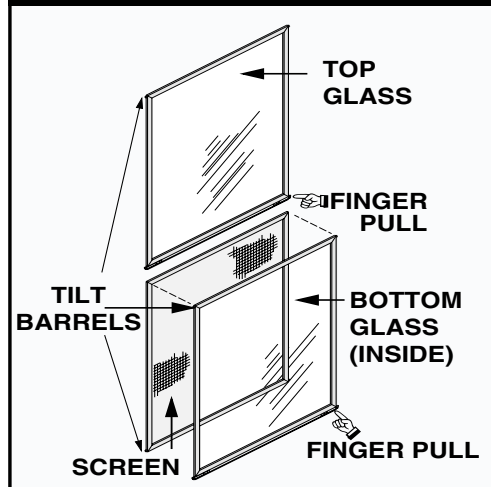

## Self-Storing (Full-Screen) Models

The 3-track design conveniently allows you to open either or both glass sashes. The full screen protects from insects regardless of the glass positions.

**NOTE: The full screen and both glass sashes MUST be installed to ensure weather-tight operation and prevent rattling of inserts.**

### TO OPERATE A SASH:

1. Retract both bottom finger-pull latches.
2. Slide the sash up or down to a notch in the track.
3. Release latches.

**NOTE: The inside sash is shorter than the outside sash so you have access to the other sashes' finger-pull latches.**

### TO REMOVE SASHES FOR CLEANING:

1. Disengage both finger-pull latches.
2. Pull out on the bottom of the sash to a nearly horizontal position.
3. Tilt the glass sash to the left to remove the top tilt keys from the track sash.  
Reinstall by reversing the previous steps.

### TO REMOVE THE FULL SCREEN FOR CLEANING:

1. Disengage the bottom pair of slide-bolts.
2. Slide screen up and pull out on bottom.
3. Release top slide bolts and remove screen.

## Ventilation Options

FIGURE 22

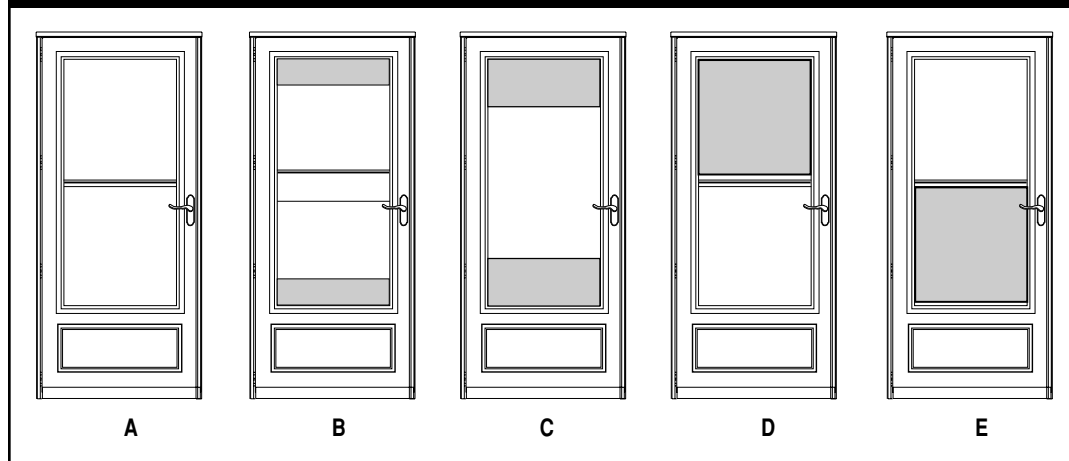

### A. NO VENTILATION

Upper glass panel: closed.  
Lower glass panel: closed.

### B. CIRCULATION VENTING

Upper glass panel: lowered one notch.  
Lower glass panel: raised one notch.

### C. TOP AND BOTTOM VENTING

Upper glass panel: lowered one to three notches.  
Lower glass panel: raised one to three notches.

### D. TOP VENTING

Upper glass panel: lowest position.  
Lower glass panel: closed.

### E. BOTTOM VENTING

Upper glass panel: closed.  
Lower glass panel: highest position

**For weather-tight operation, be sure that the narrower window panel is in the top position when re-installing the panels.**

# LARSON

## Wood-Core Series Storm/Screen Doors CLOSER INSTRUCTIONS

### 1 Closer Installation (Some models have two closers and others have one closer.)

**NOTE:** Be sure door opens and closes freely before installing the closer.

#### CLOSER ASSEMBLY PREPARATION

- Slide hold-open washer onto closer rod as shown. Pull rod out of closer so that there is a approximately 1/4" gap per Figure 1 (insert small screwdriver in rod hole to provide pulling grip). Position washer behind flanges and against the closer. **Remove screwdriver.** This will give proper tension for installation. (Do not change until installation is complete.) See Figure 1.
- Attach brackets to closer as shown in Figure 2. Attach **front** hole in closer to door bracket (**long** connecting pin). Attach closer rod to side jamb bracket (**short** connecting pin) with **open side** of jamb bracket toward storm door (see arrow on bracket). **Your closer assembly is now ready to be attached to inside of door.**
- Close and latch door.

FIGURE 1

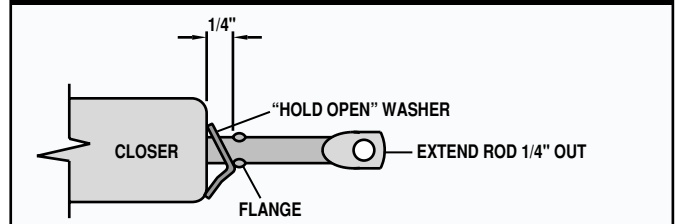

#### 1a One Closer Models

##### CLOSER ASSEMBLY INSTALLATION:

- To install the closer, hold closer assembly 3" below door window and hold jamb bracket 1/4" back from storm door. Mark jamb bracket holes and two holes in door bracket.
- Fasten jamb bracket to jamb with four #10x1-1/2" screws (see Figure 3). The **open** side of the jamb bracket should be toward the storm door (**see arrow on bracket**).
- Close and latch the door.** Hold the closer and door bracket level and mark the location for the insertion of the door bracket screws. Drill 1/8" starter holes. **CAUTION: Do not drill through the outside of door.** Install two #12 x 5/8" screws in bracket. (see Figure 3)
- To hold the door open: Open door. Slide hold-open washer over flanges toward cylinder on closer.

FIGURE 2

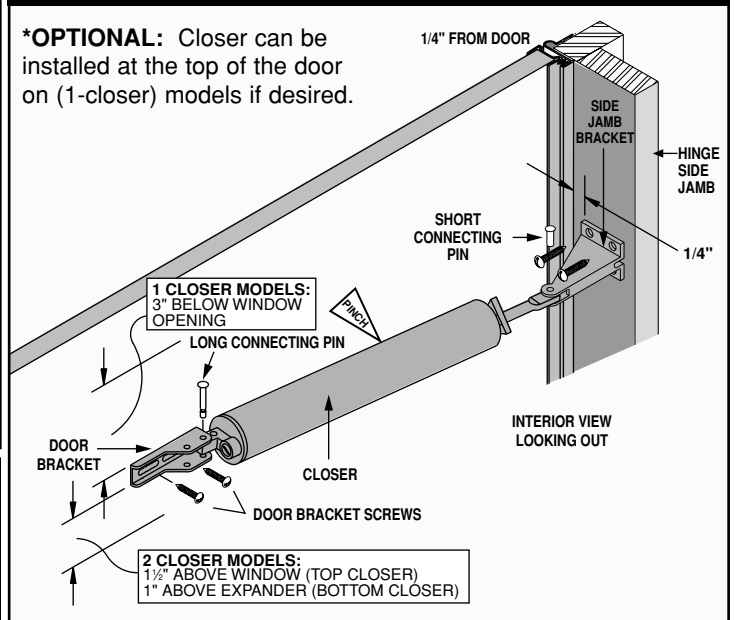

#### 1b Two Closer Models

- To install the top closer, hold closer assembly 1-1/2" above door window and hold jamb bracket 1/4" back from storm door. Mark jamb bracket holes and two holes in door bracket.
- Fasten jamb bracket to jamb with four #10x1-1/2" screws (Figure 3). The **open** side of the jamb bracket should be toward the storm door (**see arrow on bracket**).
- Close and latch the door.** Hold the closer and door bracket level and mark the location for the insertion of the door bracket screws. Drill 1/8" starter holes. **CAUTION: Do not drill through the outside of door.** Install two #12 x 5/8" screws in bracket. (see Figure 3)
- To install **bottom** closer, hold assembly level 1" above the expander and hold jamb bracket 1/4" from storm door. Mark and attach as shown in steps 1, 2, and 3. **NOTE:** Bottom closer may need to be applied over the door expander in some cases.
- To hold the door open: Open door. Slide hold-open washer over flanges toward cylinder on closer.

FIGURE 3

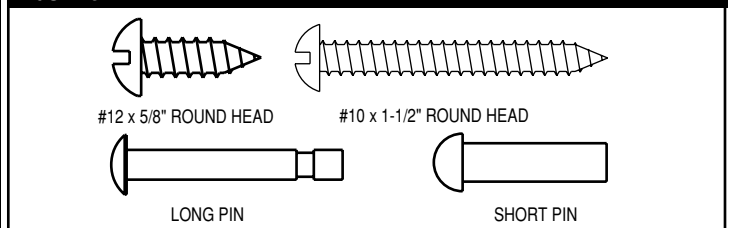

## 2 Controlled Latching Power Feature

Installed as directed, with door bracket connected to the FRONT hole of closer, the door will accelerate its closing speed in the last few inches of travel. This attachment position is recommended when the glass storm panel is in place.

If a smoother, quieter closing action is desired, hold door open about 8" with hold-open washer. Move in from door bracket and relocate in closer REAR hole. This position is normally used when the screen panel is in place.

On two closer models, **adjust each closer individually** (with the other closer disconnected from the door) to the closing speed sufficient to latch the door. The closing speed for each closer should be the same.

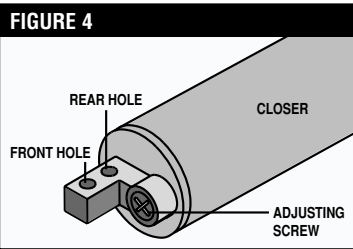

To change closing speed, turn screw on the end of closer tube clockwise for slower and counter clockwise for faster. (Figure 4)

See Troubleshooting, Symptom E for more adjustment information.

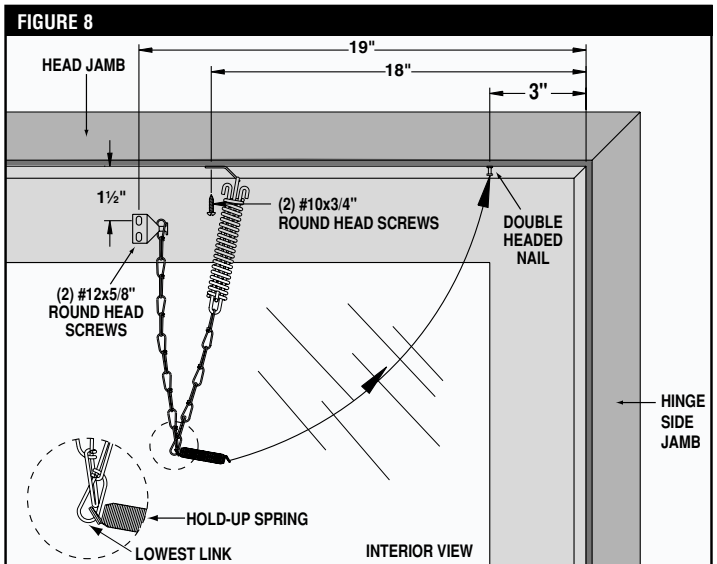
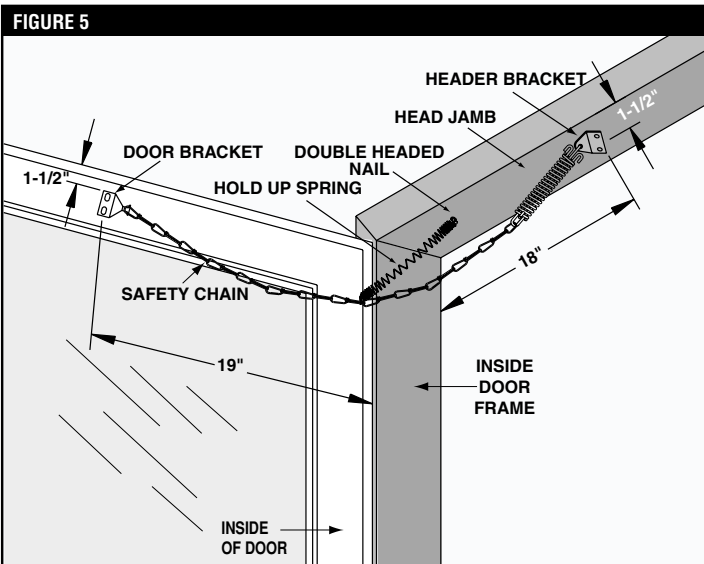

**NOTE:** Some models have screw covers, some do not.

## Z-Bar Screw Cover Installation

1. After the door is installed, apply the drip cap screw cover. Cut screw cover to correct length if needed using a scissors or a tin snip. Attach screw cover per illustration. Starting at one end, snap the cover on working your way towards the other end.
2. Cut the latch and hinge z-bar screw covers to length—matching the z-bar lengths respectively.
3. Attach the latch and hinge z-bar screw covers as described in step #1.

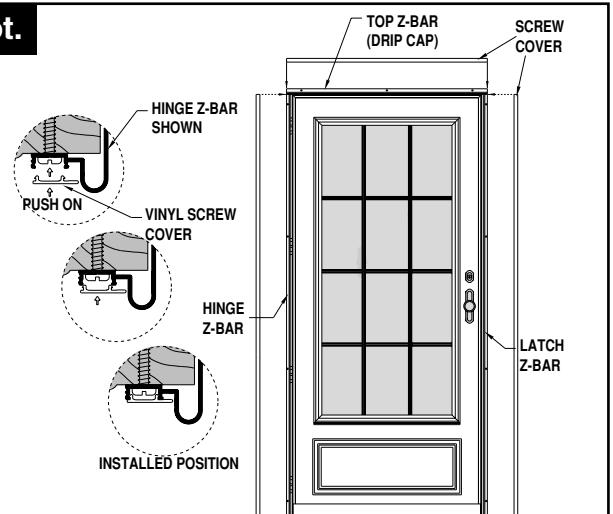

## 3 Wind Safety Chain Installation

**NOTE:** Some models do **NOT** come with a safety chain.

To attach safety chain, position the header bracket on the head jamb 18" in from the hinge side of the door frame and 1-1/2" back from the front of jamb (Figure 5). Mount this bracket at approximately 45 degrees (pointing towards door bracket when door is open). Mark location of the holes and drill two pilot holes with a 1/8" bit about 3/8" deep. Mount header bracket with two #10x3/4" round head screws (Figure 6).

Mount door bracket on the inside door surface 1-1/2" from top edge of the door and 19" from hinge edge of the door in a horizontal position. Use two (2) #12x5/8" round head screws (Figure 7). This allows door to open 90 degrees. If greater opening is desired, mount each bracket slightly closer to hinge edge of door. To allow full opening or removal of door, detach chain from bracket.

To attach hold-up spring, close the door and thread one end of the spring onto the lowest link of the chain (Figure 8).

Swing wind chain up towards hinge side of door and attach hold-up spring to head jamb with doublehead nail about 3" in from side jamb (Figure 8). Hold-up spring should not be stretched over 1/4" when door is closed.

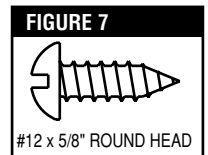
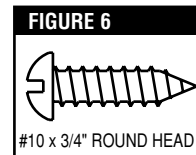



# WOOD-CORE TROUBLESHOOTING

|          | SYMPTOM                                  | POSSIBLE CAUSE  | SOLUTION  |
|----------|--|---|---|
| <b>A</b> | Door binding.                            | Hinge to Jamb screws are too tight.   | Back off screws 1/4 of a turn.  |
|          |  | Door opening out of square.   | Square up opening.  |
|          |  | Expander dragging on threshold.   | Raise expander so that bottom of sweeps only touch top of threshold.  |
|          |  | Hinge z-bar is bent.  | Replace.  |
| <b>B</b> | Door squeaking when opening.             | Hinge to Jamb screws are too tight.   | Back off screws 1/4 of a turn.  |
|          |  | Door opening is out of square.  | Square up opening.  |
|          |  | New hinges are tight.   | Lubricate with 3-in-1 oil, cooking oil, or a silicone spray lubricant.  |
|          |  | Hinges rubbing against wood jamb.   | Chisel wood out from under individual hinge. Use a utility knife.   |
| <b>C</b> | Sash retainers fall out.                 | Warped or deformed.   | Replace. Call 1-888-483-3768  |
|          |  | Improper installation.  | With retainer strips removed, center glass or screen assembly in the opening. To install the retainers, start one end of the retainer into the track at the top or bottom of window and push retainer into track. Continue to snap retainer into place moving toward the opposite end in 4 to 5-inch increments. At the end, you will hear a "snap" as the last portion of the retainer goes in. Refer to picture in the instruction manual.  |
| <b>D</b> | Door leaking.                            | Screen in position for top ventilation. (Self-Storing models)                 | Move screen to bottom ventilation.  |
|          |  | Drainage holes blocked.   | Inspect drainage holes located on outside of door below window.   |
| <b>E</b> | Door not closing (slowly or not at all). | Unpainted portion of closer rod extended beyond 1/16"                         | Readjust door bracket to allow only 1/16" or less of the unpainted portion of closer rod showing.<br>To double check: Close door, measure distance from center of hole in closer rod to the center of the <b>OUTER</b> hole on the closer itself—distance should be: (12-3/4" for a V150 closer) and (12-11/16" for a V920 closer)  |
|          |  | Closer speed improperly adjusted.   | Recheck instruction manual for proper closer installation. Proceed by removing the closer adjusting screw from the closer. Fully open door and allow it to close (door should slam shut). Reinstall closer adjusting screw allowing only 1 or 2 threads of the screw to be turned in. Fully open door and allow the door to close. Adjust the screw 1/4 to 1/2 turn to achieve the desired closing speed sufficient to latch door. NOTE: On two closer models adjust each closer individually (with the other closer being disconnected from the door); the closing speed should be the same for each closer). If more latching force is desired, the jamb bracket may be moved up to 1" away from the door (rather than the recommended 1/4"). NOTE: moving the jamb bracket further from the door reduces the door opening. |
|          |  | Air pressure between prime door and storm door (back pressure being created). | Raise expander or leave window open to allow air to escape.   |

Aluminum Wood Core doors need to have the surface scrubbed with steel wool, sand paper (very fine grit), or a ScotchBrite pad to remove the sheen (gloss), then cleaned with a solvent to remove any grease or oils. Apply an epoxy primer. Top coat with a premium grade of solvent-based acrylic lacquer or solvent-based enamel paint. For best results, have it painted at a professional body shop. Larson Manufacturing does not recommend that Vinyl or DuraTech skin material be painted as it can cause deterioration of the skin or bubbling. If the skin is painted the warranty is void.





## Larson Storm Door Warranties

**Applies to Original Purchaser of Door Only**  
**Covers manufacturer's defects only**

| <b>Door Series</b>   | <b>Warranty</b>   |
|--|---|
| <b>PRESTIGE SEAL</b><br><i>Limited Lifetime Warranty</i>       | During the first 20 years, Larson Manufacturing will warranty all manufacturer's defects at no charge to the consumer. After 20 years, the consumer will be responsible for any shipping and handling charges of warranty replacements.   |
| <b>LIFESTYLE BY LARSON</b><br><i>Limited Lifetime Warranty</i> | During the first 20 years, Larson Manufacturing will warranty all manufacturer's defects at no charge to the consumer. After 20 years, the consumer will be responsible for any shipping and handling charges of warranty replacements.   |
| <b>LIFE-CORE</b><br><i>Limited Lifetime Warranty</i>           | During the first 10 years, Larson Manufacturing will warranty all manufacturer's defects at no charge to the consumer. After 10 years, the consumer will be responsible for any shipping and handling charges of warranty replacements.   |
| <b>VALUE-CORE</b><br><i>Limited Lifetime Warranty</i>          | During the first 5 years, Larson Manufacturing will warranty all manufacturer's defects at no charge to the consumer. After 5 years, the consumer will be responsible for any shipping and handling charges of warranty replacements.   |
| <b>VINYL-CLAD</b><br><i>Five-Year Warranty</i>                 | During the first 2 years, Larson Manufacturing will warranty all manufacturer's defects at no charge to the consumer. After 2 years until the end of the fifth year, the consumer will be responsible for any shipping and handling charges of warranty replacements.                           |
| <b>HARDWARE</b>  | Hardware warranty is 1 year, covering workmanship and mechanical parts. Brass finish is not covered under the warranty. Brass is like fine silver; it needs occasional maintenance. To maintain your brass finish, see the "General Care and Maintenance" section of installation instructions. |

**Storm Door Warranty Limitations:**

- Modification of door will void warranty.
- Screen/glass damage or breakage is not covered under warranty.
- Wind damage is not covered under warranty.
- Warranty applies to original homeowners of owner-occupied residential properties and covers manufacturer's defects.
- Labor cost, reinstallation fees are not covered by warranty.

In order to obtain warranty replacements, proof of purchase is required. Customers should call our customer service hotline at **1-888-483-3768** or visit our web site at [www.larsondoors.com](http://www.larsondoors.com) When placing the call, please have registration number available.

**NOTE: Warranty applies to original owner—only. Proof of purchase is required.**

# Storm Door General Care and Maintenance



|                                       |   |
|---------------------------------------|---|
| <b>Glass</b>                          | Wash glass using a household glass cleaner, or a warm water/mild detergent mixture, and a soft cloth or paper towel.  |
| <b>Brass Inlaid Glass</b>             | Use only warm water to clean the glass portion of brass inlaid glass. Do <b>NOT</b> use household glass cleaners on brass inlaid glass. Many cleaners containing ammonia will expedite tarnishing of brass. For brass cleaning, see the “Brass Products” section.   |
| <b>Door Finish</b>                    | <p><b>DuraTech Surface</b>—For general cleaning, the following products may be used: Ivory (soap and water solution), Formula 409, Windex, Spic and Span, Scrubbing Bubbles, Fantastik, Simple Green, Pine Sol, Isopropanol. Always follow manufacturer’s directions. Using a soft, clean cloth, apply the cleaner, and clean only a small portion of the surface at one time. After cleaning, rinse off the surface as completely as possible. For heavy cleaning use regular SoftScrub (SoftScrub with Bleach may slightly abrade surface), Bug and Tar Remover, or OOPS. Never use Acetone, or products containing esters, ethers, ketones, aromatic and chlorinated hydrocarbons.</p> <p>For stain removal (white surfaces only), apply liquid bleach to a paper or cloth towel. Place the towel over a portion of the stain, keeping the towel moist for a period of at least five minutes. Remove the towel and thoroughly wash off the bleach. If necessary, repeat the application of the towel and bleach. NOTE: This information is provided for your guidance only. We urge you to test a small area prior to use.</p> <p><b>Aluminum Skin</b>—Non-abrasive paste wax may be used on your door’s outer surface to help keep the finish looking new. (Follow directions on the product’s label.)</p> <p><b>Vinyl Skin</b>—Wash using a warm water/mild detergent mixture, and a soft cloth.</p> |
| <b>Hinges/Hardware</b>                | Hinges and door hardware may require occasional lubrication. A silicone spray lubricant is recommended.   |
| <b>Brass-tone Expander (Anodized)</b> | Wash expander using a warm water/mild detergent mixture, and a soft cloth. Do not use a brass cleaner or steel wool. This is <b>NOT</b> a real brass product.)  |

---

## Brass Finish Maintenance

A number of Larson storm door models incorporate high quality “real” brass component parts. As with all brass products, tarnishing will occur. Without proper care, brass can become stained so heavily that cleaning cannot totally remove the stain. In extreme cases of neglect, pitting can occur.

Larson locksets and deadbolts have a clear coat finish. Clear coat finishes will protect against tarnishing. If the clear coat finish is damaged, tarnishing will occur. Larson brass, inlaid in the glass, does not have a clear coat finish. It requires periodic cleaning and polishing to maintain the shiny brass appearance.

### ***Brass Inlaid Glass Inserts***

Clean and polish as directed below every two to three weeks when brass is used in outdoor applications. Four to five week intervals are recommended for indoor applications.

#### **•For normal cleaning situations, including mild tarnishing:**

1. Apply small amounts of brass cleaner (i.e. Brasso, Tarni-Shield) with a clean soft cotton cloth per manufacturer’s directions.
2. Be careful not to allow excess cleaner to be deposited on the glass surface.
3. Do not allow cleaner to “cake” between edges of brass and the glass surface.
4. Should “caking” occur, use a toothbrush or similar nylon, stiff bristle brush to gently loosen and remove excess material.

#### **•For solder joints and heavily tarnished brass:**

1. Buff lightly with #0000 size steel wool until bright brass finish returns. Use small pieces of steel wool, so that “wool overhang” will not scratch the glass surface. Note: Heavily tarnished brass will require more buffing pressure than the softer solder joint material.
2. Clean the brass, applying small amounts of brass cleaner per manufacturer’s instructions as described above.

### ***Brass Locksets, Deadbolts, Name Plates***

#### **•Cleaning**

1. Wash brass hardware using a warm water/mild detergent mixture, and a soft cloth. Do not use abrasive cleaners or cloths as they may damage the clear coat finish.
2. Apply non-abrasive paste wax on the brass hardware to help restore it’s bright finish.

**Questions? Call the Larson Homeowner Helpline at 1-888-483-3768.**